

TerraCast® PRODUCTS

TerraCast® Products, LLC
4400 NW 19th Avenue, Unit K
Pompano Beach, FL 33064
Office: 305-895-9525 x105
Fax: 305-895-7879

- Resin Construction
- Will Not Rust!
- In-ground Mounting
- 120 V
- White Frosted Lens
- Compact Fluorescent
or
LED Available
- 5-42 Watts
- 9.5'' Square x 41'' Tall

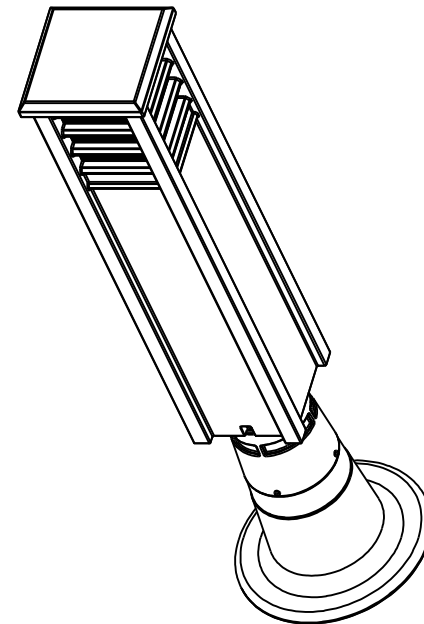
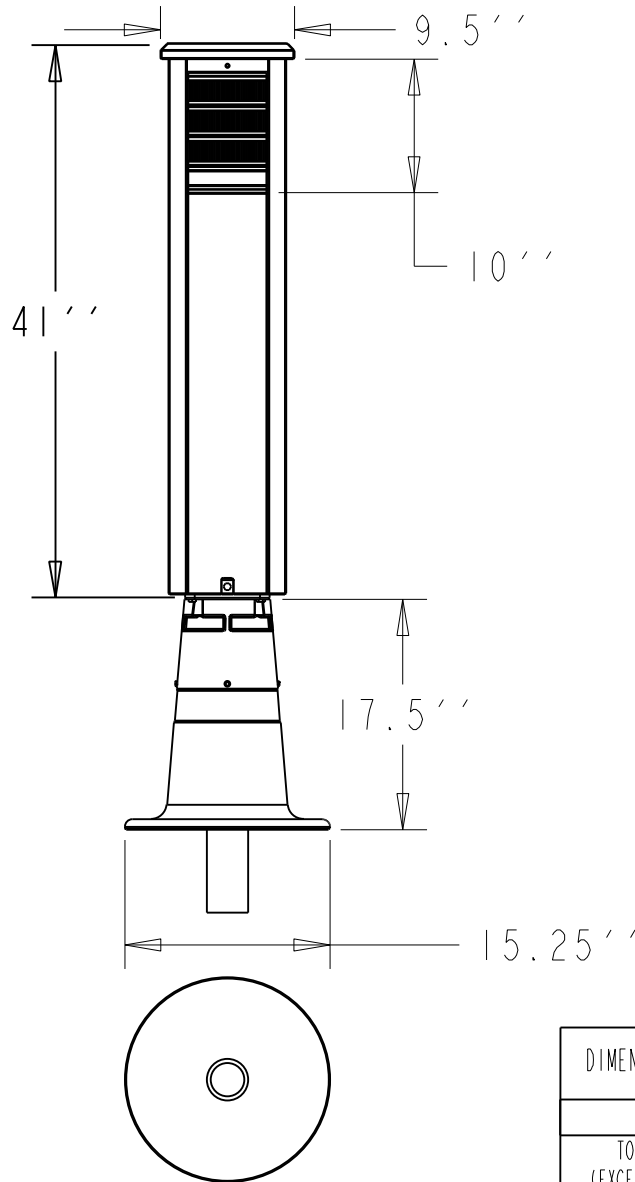

REVISIONS				
REV	DESCRIPTION	ECN	DATE	APPROVED
XI	PRELIMINARY	----	-----	

DIMENSION UNITS	TerraCast® PRODUCTS			
TOLERANCES (EXCEPT AS NOTED)	MATERIAL:	SCALE 0.070	DRAWN BY www.Terracastproducts.com	
XX = ±0.01 XXX = ±0.001	TITLE			I OF I
ANGULAR ±0.5	DATE Feb-05-16	PART #: (A SIZE)	41-SQUARE-BOLLARD	REV XI

This document contains TERRACAST PROPRIETARY INFORMATION. No intellectual property right or license is granted by TERRACAST in connection with it. It is delivered on the express condition that the document and the information contained in it shall be treated as confidential, shall not be used for and purpose other than that for which it is hereby delivered (the use and maintenance of the product supplied). It shall not be disclosed in whole or part to third parties and shall not be duplicated in any manner without TERRACAST's prior written consent.