

TerraCast[®]

PRODUCTS

TerraCast® Products, LLC
 4400 NW 19th Avenue, Unit K
 Pompano Beach, FL 33064
 Office: 305-895-9525 x105
 Fax: 305-895-7879

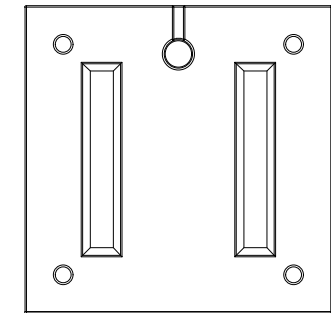
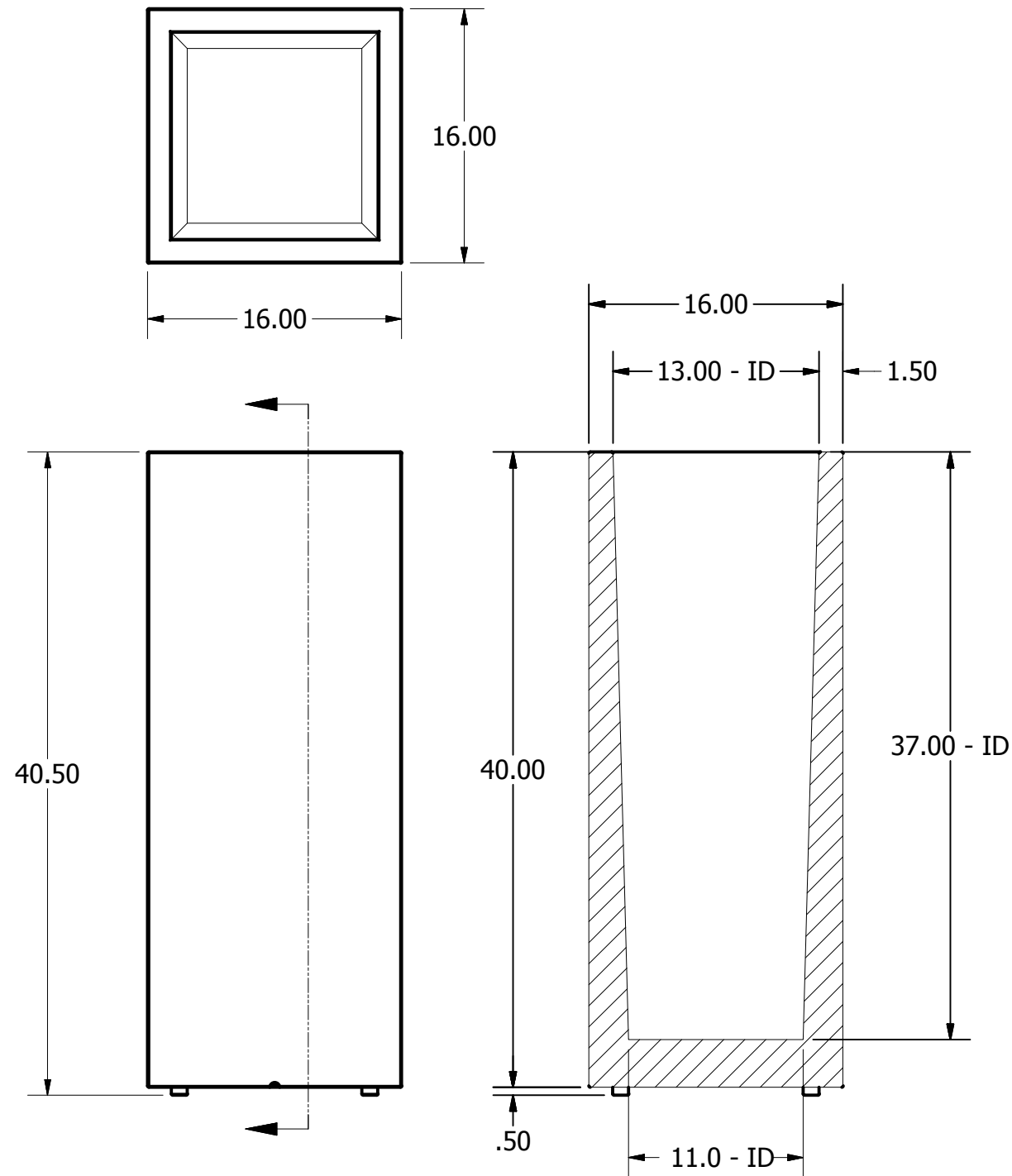
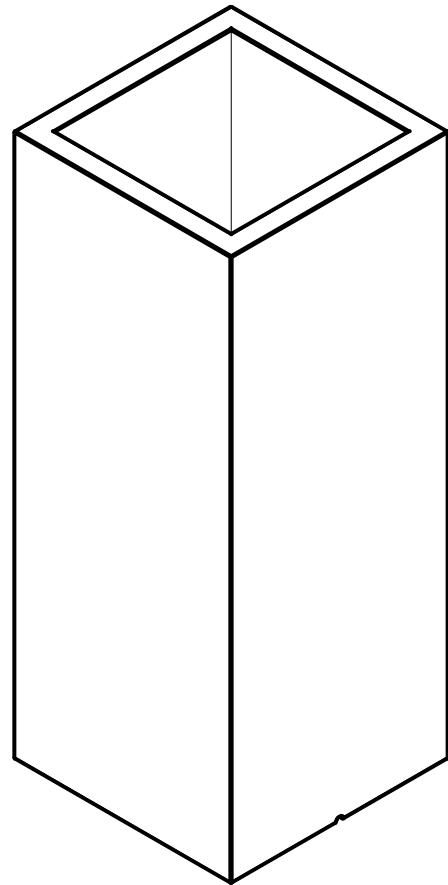

BOTTOM VIEW

SPECS AT A GLANCE	
DESCRIPTION	DIMENSION
TOP ID	13" x 13"
TOP OD	16" x 16"
BOTTOM ID	11" x 11"
OVERALL HT	40.5"
INSIDE HT	37"
FEET	0.5" Height
LIP	1.5" Wide
WEIGHT	38lbs

REVISIONS				
REV	DESCRIPTION	ECN	DATE	APPROVED

This document contains TERRACAST PROPRIETARY INFORMATION. No intellectual property right or license is granted by TERRACAST in connection with it. It is delivered on the express condition that the document and the information contained in it shall be treated as confidential, shall not be used for and purpose other than that for which it is hereby delivered (the use and maintenance of the product supplied). It shall not be disclosed in whole or part to third parties and shall not be duplicated in any manner without TERRACAST's prior written consent.

Dimensions Units	TerraCast P R O D U C T S			
	INCH	Material: LLDPE	Scale: 1:10	Drawn by:
	Tolerance (except as noted)	Title: Millennium Straight Square 16-40		1 of 1
	xx: ±0.01 xxx: ±0.001	Date: 03/06/2019	Part # (A SIZE) TSS 16-40	REV A
Angular	±0.5			