

TerraCast[®]

PRODUCTS

TERRACAST PRODUCTS LLC
 4400 NW 19TH AVENUE, UNIT K
 POMPANO BEACH, FL 33064
 OFFICE: 305-895-9525 X105
 FAX: 305-400-0547

SPECS AT A GLANCE

LENGTH: 20-1/2''

WIDTH: 20-1/2''

HEIGHT: 16-3/4''

WEIGHT: 12 LBS.

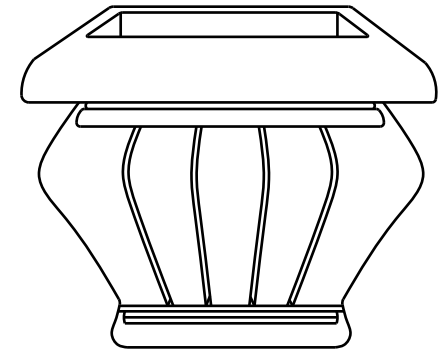
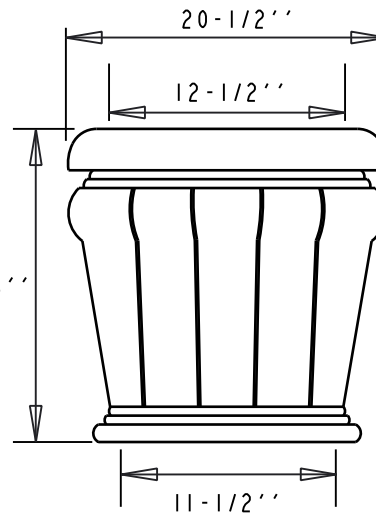
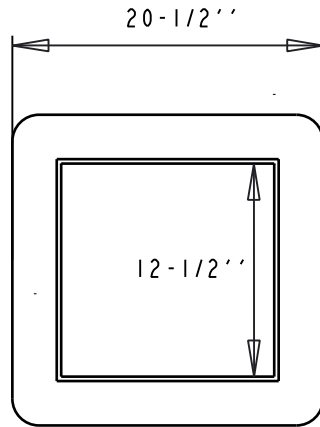

REVISIONS				
REV	DESCRIPTION	ECN	DATE	APPROVED
XI	PRELIMINARY	----	-----	

Part Number - GY21

DIMENSION UNITS		TerraCast[®] PRODUCTS		
INCHES	MATERIAL:	SCALE	DRAWN BY	
TOLERANCES (EXCEPT AS NOTED)	LLDPE RESIN	0.030	TERRACAST	
XX = ±0.25	TITLE			1 OF
XXX = ±0.250	ROMAN SQUARE			
ANGULAR	DATE	PART #:	REV	
+0.5		(A SIZE) GY21	XI	

This document contains TERRACAST PROPRIETARY INFORMATION. No intellectual property right or license is granted by TERRACAST in connection with it. It is delivered on the express condition that the document and the information contained in it shall be treated as confidential, shall not be used for and purpose other than that for which it is hereby delivered (the use and maintenance of the product supplied). It shall not be disclosed in whole or part to third parties and shall not be duplicated in any manner without TERRACAST's prior written consent.