

TerraCast[®]

PRODUCTS

TERRACAST PRODUCTS LLC
 4400 NW 19TH AVENUE, UNIT K
 POMPANO BEACH, FL 33064
 305-895-9525
 INFO@TERRACASTPRODUCTS.COM

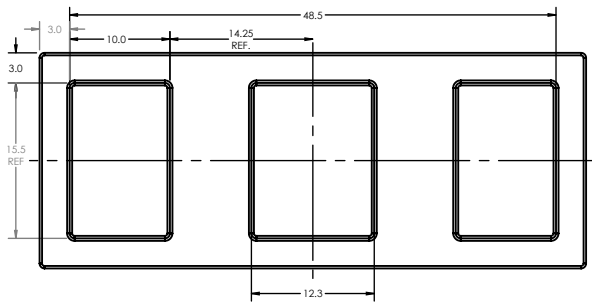
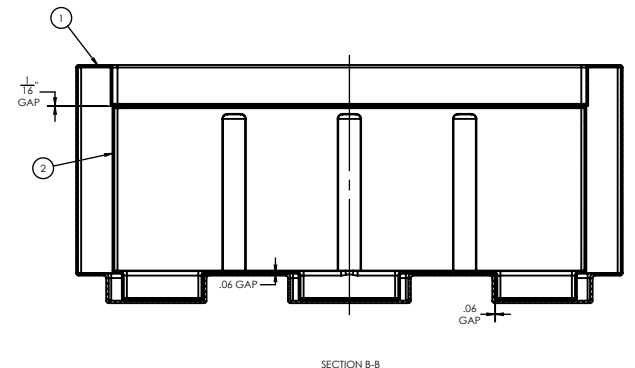
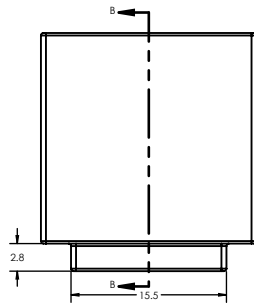
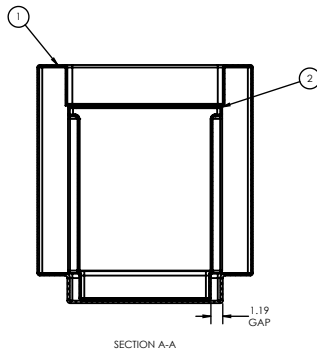
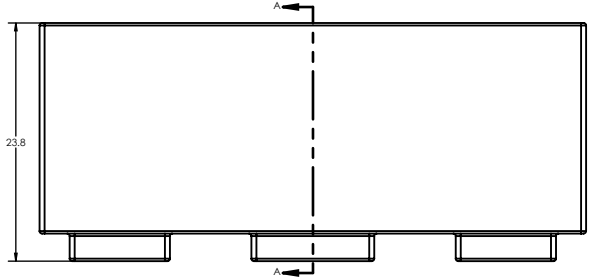
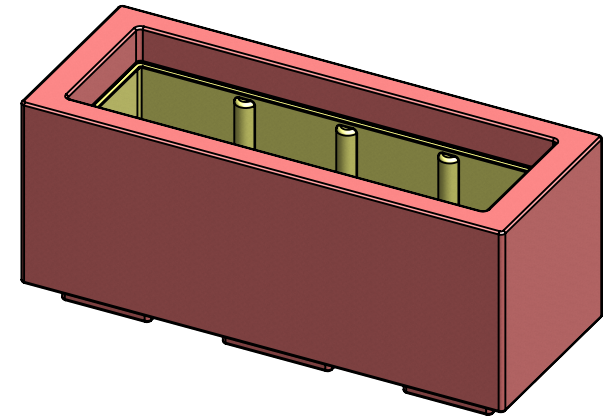
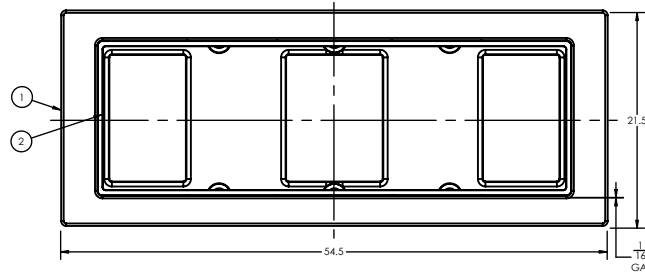

SPECS AT A GLANCE

TOP ID: 48.5" x 15.5"
 TOP OD: 54.5" x 21.5"
 BASE ID: 48.5" x 15.5"
 BASE OD: 54.5" x 21.5"
 HEIGHT: 23.8"
 WEIGHT: 58 LBS

NOTE:
 COMBINED ASSEMBLY TO WEIGH APPROX. 58 LBS. AFTER TRIMMING AT 3/16" WALL.

ITEM NO.	PART NUMBER	QTY.
1	55x22x24 Millennium Planter Shell	1
2	55x22x24 Millennium Planter Liner 3	1

DO NOT SCALE DRAWING.
 All measurements are rounded to the closest quarter inch and may not be exact due to manufacturing variances.
 This document contains TERRACAST[®] PROPRIETARY INFORMATION. No intellectual property right or license is granted by TERRACAST[®] in connection with it. It is delivered on the express condition that the document and the information contained in it shall be treated as confidential, shall not be used for and purpose other than that for which it is hereby delivered (the use and maintenance of the product supplied). It shall not be disclosed in whole or part to third parties and shall not be duplicated in any manner without TERRACAST[®]'s prior written consent.

TerraCast [®] PRODUCTS				
TITLE Millennium Rectangular Assembly				
PART# TSR55-24			DRAWN KT	
SIZE	MATERIAL	DWG NO	DATE	REV
	LLDPE Resin		03-01-21	
SCALE		WEIGHT		SHEET 1/3

TerraCast[®]

PRODUCTS

TERRACAST PRODUCTS LLC
 4400 NW 19TH AVENUE, UNIT K
 POMPANO BEACH, FL 33064
 305-895-9525
 INFO@TERRACASTPRODUCTS.COM

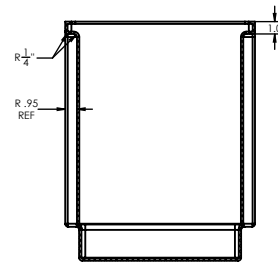
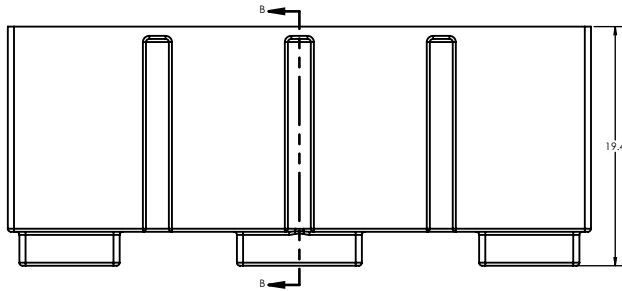
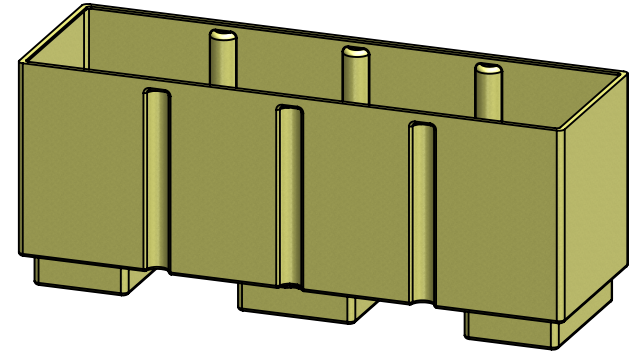
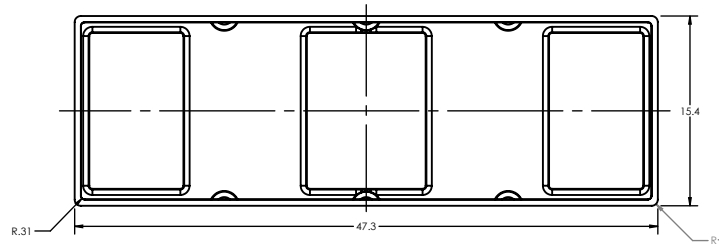

SECTION B-B

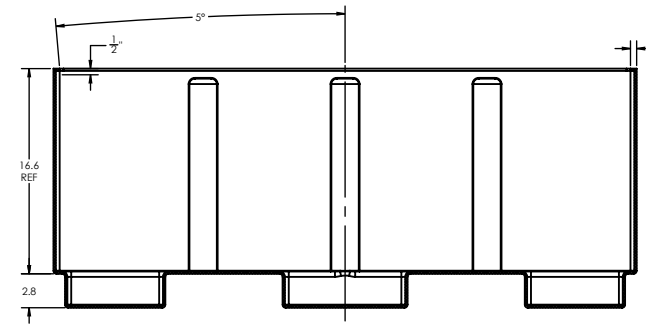
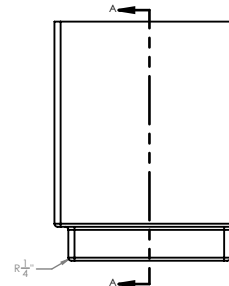

SECTION A-A

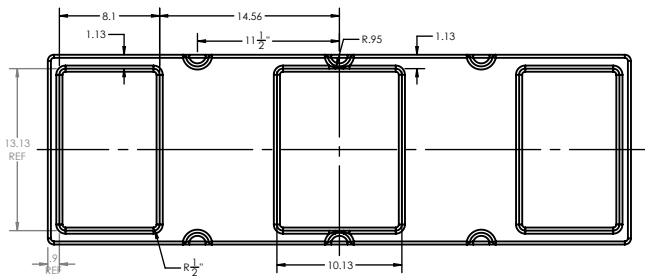

SPECS AT A GLANCE

TOP ID:
 TOP OD: 47.3" x 15.4"
 BASE ID:
 BASE OD: 47.3" x 15.4"
 HEIGHT: 19.4"
 WEIGHT: 21 LBS

NOTE:
 PART TO WEIGH APPROX. 20.5 LBS. AFTER TRIMMING AT 3/16" WALL.

TerraCast[®]
 PRODUCTS

TITLE				
Millennium Rectangular Liner				
PART#			DRAWN	
TSR55-24-Liner			KT	
SIZE	MATERIAL	DWG NO	DATE	REV
	LLDPE Resin		03-01-21	
SCALE		WEIGHT	SHEET 2/3	

DO NOT SCALE DRAWING.

All measurements are rounded to the closest quarter inch and may not be exact due to manufacturing variances.
 This document contains TERRACAST[®] PROPRIETARY INFORMATION. No intellectual property right or license is granted by TERRACAST[®] in connection with it. It is delivered on the express condition that the document and the information contained in it shall be treated as confidential, shall not be used for and purpose other than that for which it is hereby delivered (the use and maintenance of the product supplied). It shall not be disclosed in whole or part to third parties and shall not be duplicated in any manner without TERRACAST[®]'s prior written consent.

TerraCast[®]

PRODUCTS

TERRACAST PRODUCTS LLC
 4400 NW 19TH AVENUE, UNIT K
 POMPANO BEACH, FL 33064
 305-895-9525
 INFO@TERRACASTPRODUCTS.COM

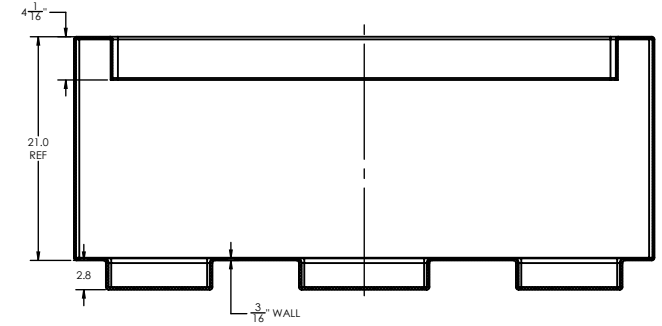
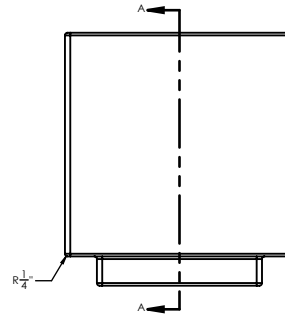
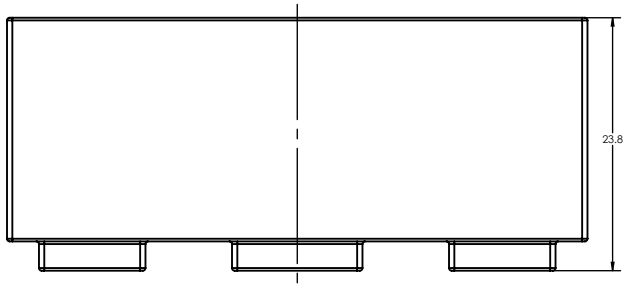
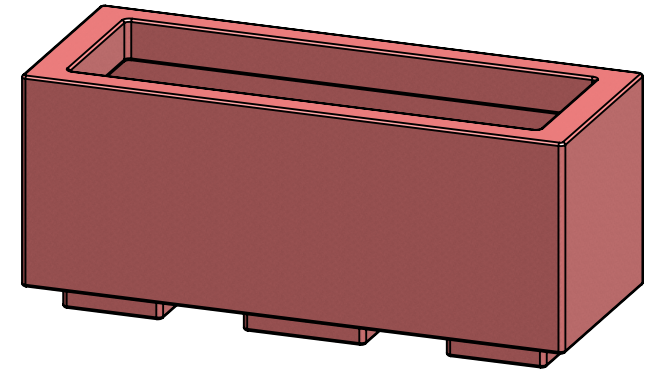
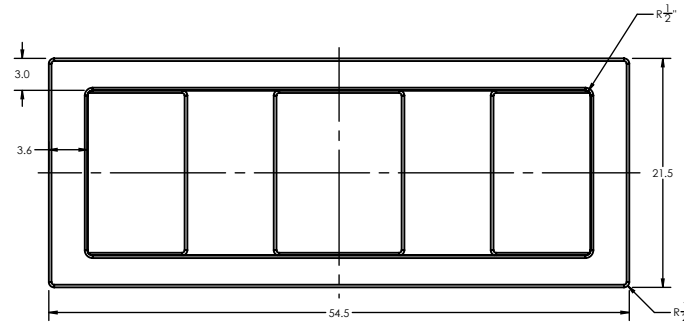

SECTION A-A

NOTE:
 PART TO WEIGH APPROX. 37.25 LBS. AFTER TRIMMING AT 3/16" WALL.

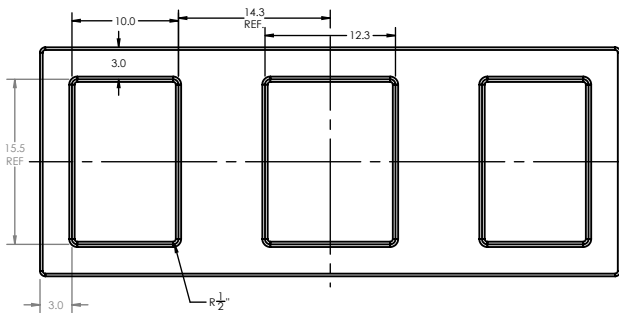

SPECS AT A GLANCE

TOP ID: 48.5" x 15.5"
 TOP OD: 54.5" x 21.5"
 BASE ID: 48.5" x 15.5"
 BASE OD: 54.5" x 21.5"
 HEIGHT: 23.8"
 WEIGHT: 37 LBS

DO NOT SCALE DRAWING.

All measurements are rounded to the closest quarter inch and may not be exact due to manufacturing variances.

This document contains TERRACAST[®] PROPRIETARY INFORMATION. No intellectual property right or license is granted by TERRACAST[®] in connection with it. It is delivered on the express condition that the document and the information contained in it shall be treated as confidential, shall not be used for and purpose other than that for which it is hereby delivered (the use and maintenance of the product supplied). It shall not be disclosed in whole or part to third parties and shall not be duplicated in any manner without TERRACAST[®]'s prior written consent.

TerraCast[®]
 PRODUCTS

TITLE

Millennium Rectangular

PART#

TSR55-24

DRAWN
 KT

SIZE

MATERIAL
 LLDPE Resin

DWG NO

DATE

03-01-21

REV

SCALE

WEIGHT

SHEET 3/3