

# TerraCast<sup>®</sup>

## PRODUCTS

TERRACAST PRODUCTS LLC  
 4400 NW 19TH AVENUE, UNIT K  
 POMPANO BEACH, FL 33064  
 305-895-9525  
 INFO@TERRACASTPRODUCTS.COM

ITEM NO.	PART NUMBER	QTY.
1	36x30 Millennium Planter Shell	1
2	36x30 Millennium Planter Liner 3	1

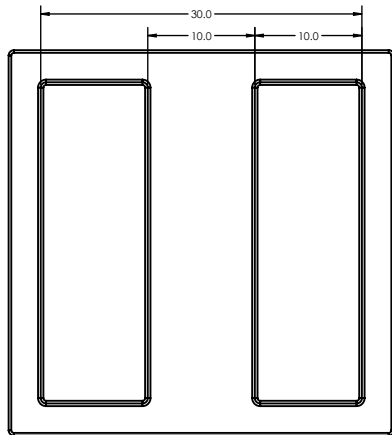
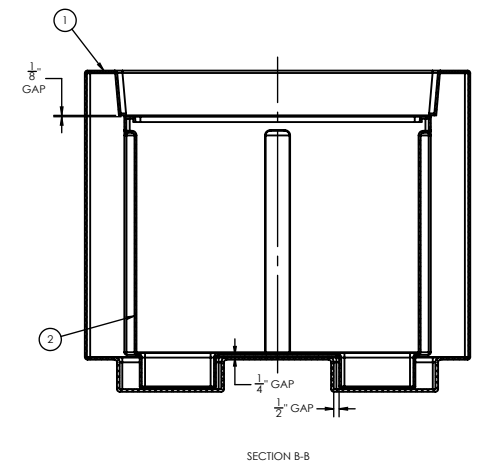
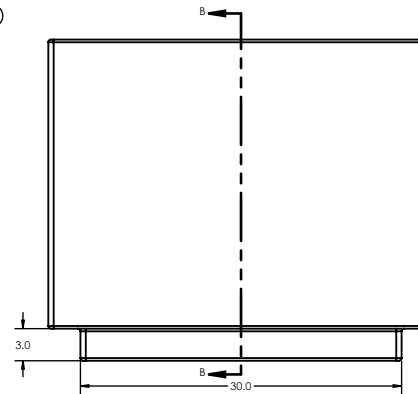
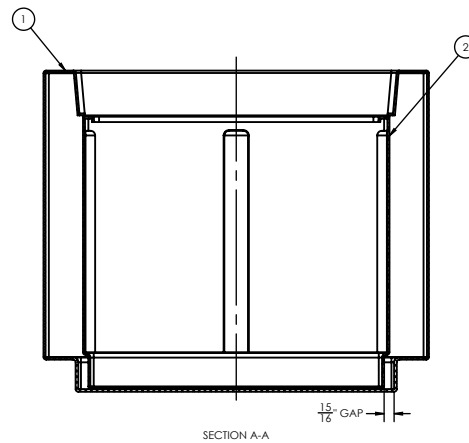
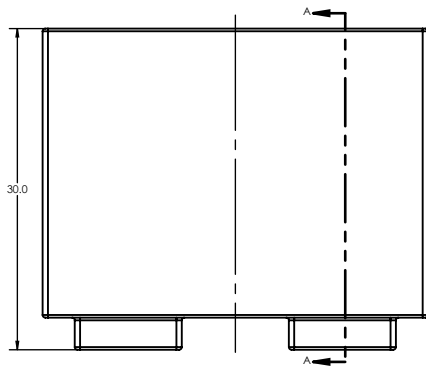
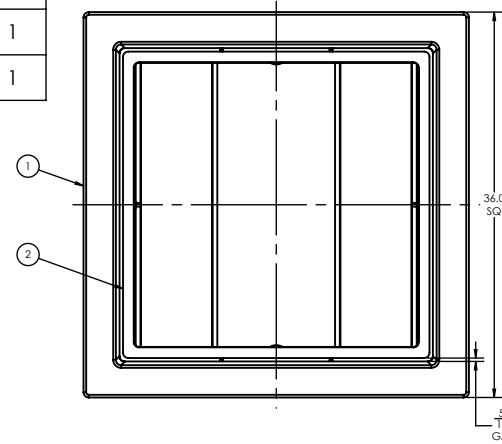
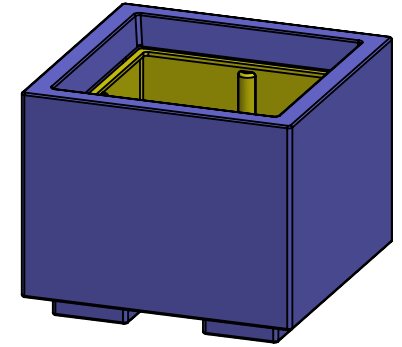

### SPECS AT A GLANCE

TOP ID: 26" x 26"  
 TOP OD: 36" x 36"  
 BASE ID: 27.5" x 27.5"  
 BASE OD: 36" x 36"  
 HEIGHT: 30"  
 WEIGHT: 68 LBS

NOTE:  
 COMBINED ASSEMBLY TO WEIGH APPROX. 67.75 LBS. AFTER TRIMMING AT 3/16" WALL.

DO NOT SCALE DRAWING.  
 All measurements are rounded to the closest quarter inch and may not be exact due to manufacturing variances.  
 This document contains TERRACAST<sup>®</sup> PROPRIETARY INFORMATION. No intellectual property right or license is granted by TERRACAST<sup>®</sup> in connection with it. It is delivered on the express condition that the document and the information contained in it shall be treated as confidential, shall not be used for and purpose other than that for which it is hereby delivered (the use and maintenance of the product supplied). It shall not be disclosed in whole or part to third parties and shall not be duplicated in any manner without TERRACAST<sup>®</sup>'s prior written consent.

# TerraCast<sup>®</sup>

PRODUCTS

TITLE

## Millennium Square Assembly

PART# TSS36-30

DRAWN  
 KT

SIZE	MATERIAL	DWG NO	DATE	REV
	LLDPE Resin		03-16-21	

SCALE	WEIGHT	SHEET 1/3
-------	--------	-----------

# TerraCast<sup>®</sup>

## PRODUCTS

TERRACAST PRODUCTS LLC  
 4400 NW 19TH AVENUE, UNIT K  
 POMPANO BEACH, FL 33064  
 305-895-9525  
 INFO@TERRACASTPRODUCTS.COM

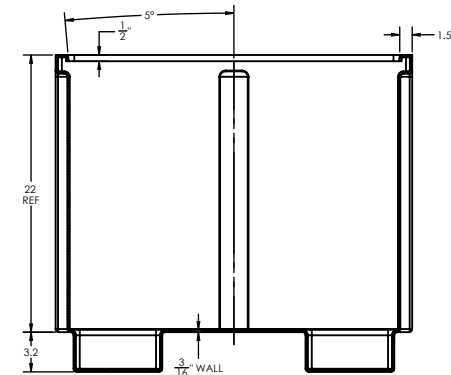
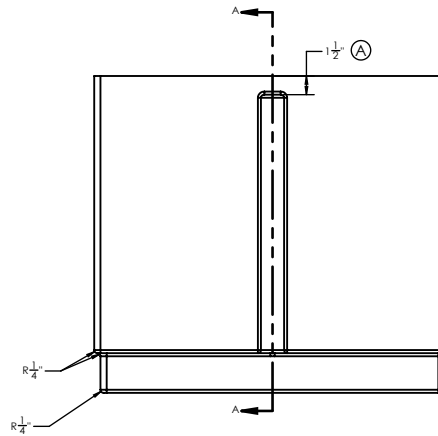
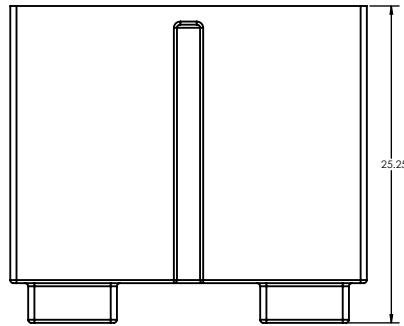
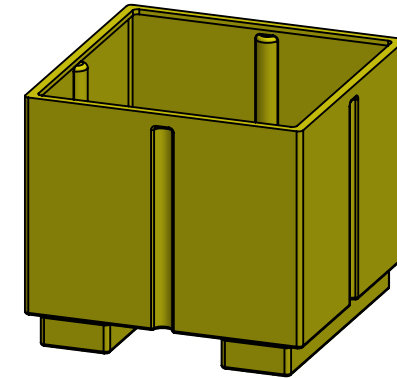
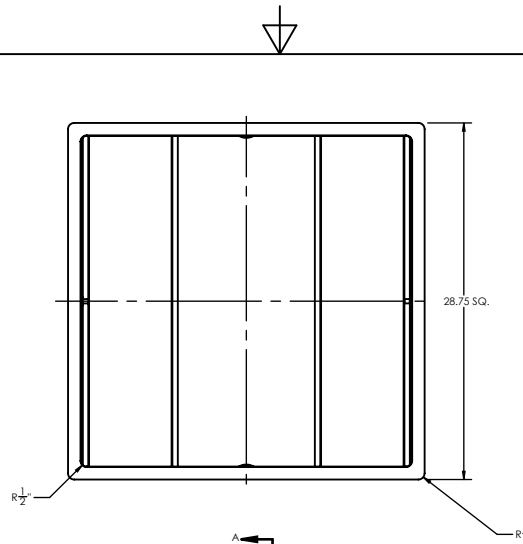

SECTION A-A

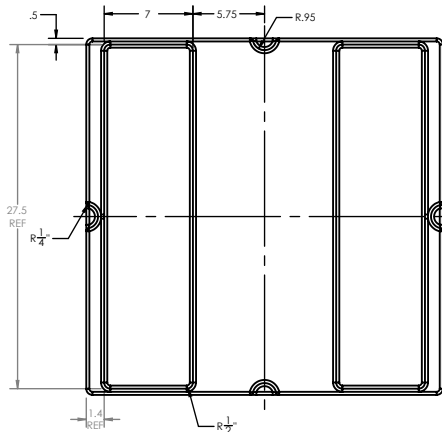

### SPECS AT A GLANCE

TOP ID: 26" x 26"  
 TOP OD: 28.75" x 28.75"  
 BASE ID: 27.5" x 27.5"  
 BASE OD: 28.5" x 28.5"  
 HEIGHT: 25.25"  
 INSIDE HT: 22"  
 WEIGHT: 25 LBS

NOTE:  
 PART TO WEIGH APPROX. 25 LBS. AFTER TRIMMING AT 3/16" WALL.

**TerraCast<sup>®</sup>**  
 PRODUCTS

TITLE

**Millennium Square Liner**

PART#

**TSS36-30-Liner**

DRAWN  
 KT

SIZE

MATERIAL  
 LLDPE Resin

DWG NO

DATE

03-16-21

REV

SCALE

WEIGHT

SHEET 2/3

DO NOT SCALE DRAWING.

All measurements are rounded to the closest quarter inch and may not be exact due to manufacturing variances.

This document contains TERRACAST<sup>®</sup> PROPRIETARY INFORMATION. No intellectual property right or license is granted by TERRACAST<sup>®</sup> in connection with it. It is delivered on the express condition that the document and the information contained in it shall be treated as confidential, shall not be used for and purpose other than that for which it is hereby delivered (the use and maintenance of the product supplied). It shall not be disclosed in whole or part to third parties and shall not be duplicated in any manner without TERRACAST<sup>®</sup>'s prior written consent.

# TerraCast<sup>®</sup>

## PRODUCTS

TERRACAST PRODUCTS LLC  
 4400 NW 19TH AVENUE, UNIT K  
 POMPANO BEACH, FL 33064  
 305-895-9525  
 INFO@TERRACASTPRODUCTS.COM

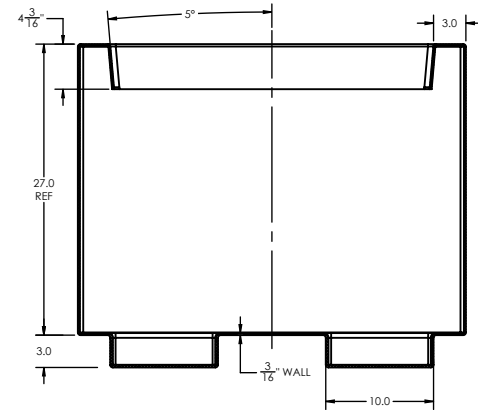
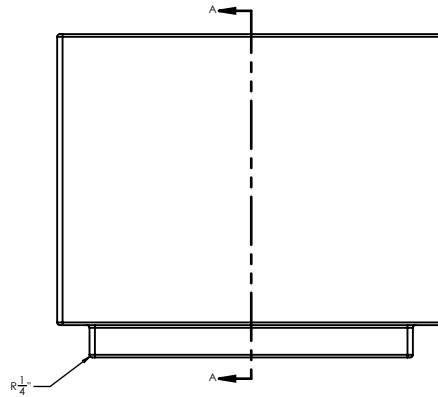
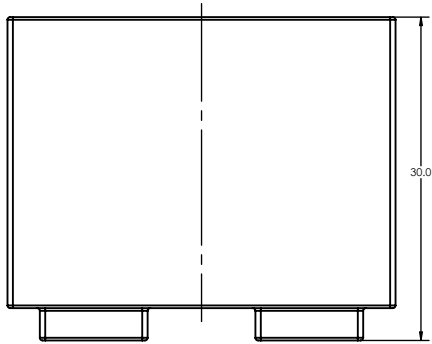
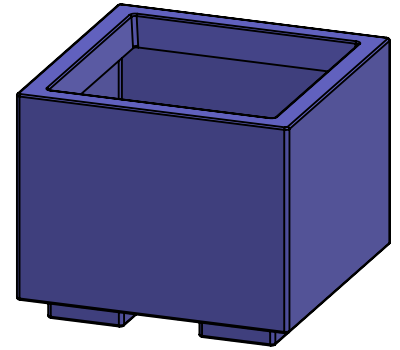
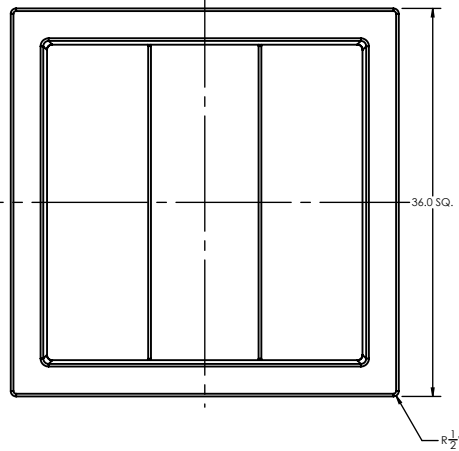

SECTION A-A

NOTE:

PART TO WEIGH APPROX. 42.75 LBS. AFTER TRIMMING AT 3/16" WALL.

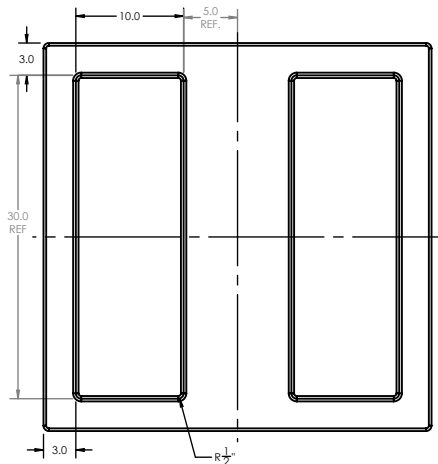

### SPECS AT A GLANCE

TOP ID: 30" x 30"  
 TOP OD: 36" x 36"  
 BASE ID: 30" x 30"  
 BASE OD: 36" x 36"  
 HEIGHT: 30"  
 WEIGHT: 43 LBS

DO NOT SCALE DRAWING.

All measurements are rounded to the closest quarter inch and may not be exact due to manufacturing variances.

This document contains TERRACAST<sup>®</sup> PROPRIETARY INFORMATION. No intellectual property right or license is granted by TERRACAST<sup>®</sup> in connection with it. It is delivered on the express condition that the document and the information contained in it shall be treated as confidential, shall not be used for and purpose other than that for which it is hereby delivered (the use and maintenance of the product supplied). It shall not be disclosed in whole or part to third parties and shall not be duplicated in any manner without TERRACAST<sup>®</sup>'s prior written consent.

# TerraCast<sup>®</sup>

PRODUCTS

TITLE

## Millennium Square Shell

PART#

### TSS36-30

DRAWN  
KT

SIZE

MATERIAL  
LLDPE Resin

DWG NO

DATE

03-16-21

REV

SCALE

WEIGHT

SHEET 3/3