

TerraCast[®]

PRODUCTS

TERRACAST PRODUCTS LLC
 4400 NW 19TH AVENUE, UNIT K
 POMPANO BEACH, FL 33064
 305-895-9525
 INFO@TERRACASTPRODUCTS.COM

ITEM NO.	PART NUMBER	QTY.
1	48x24x24 Millennium Planter Shell	1
2	48x24x24 Millennium Planter Liner	1

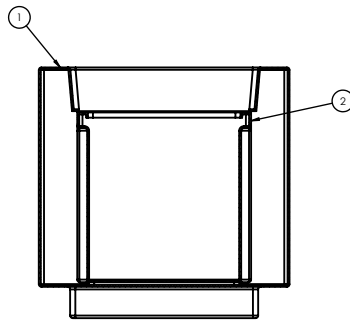
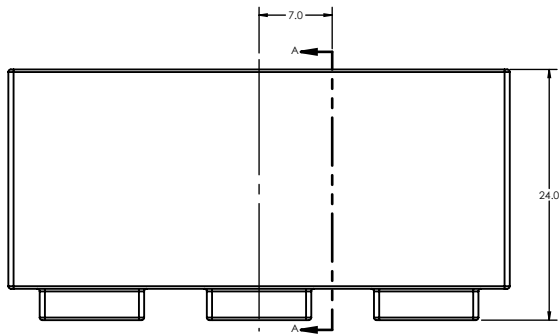
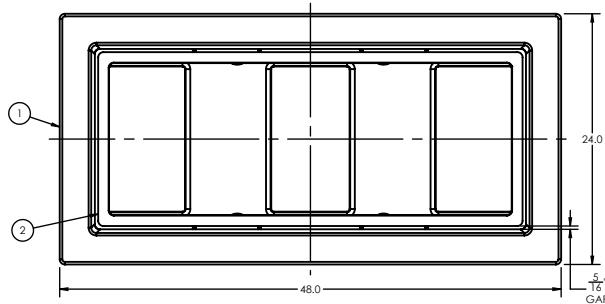
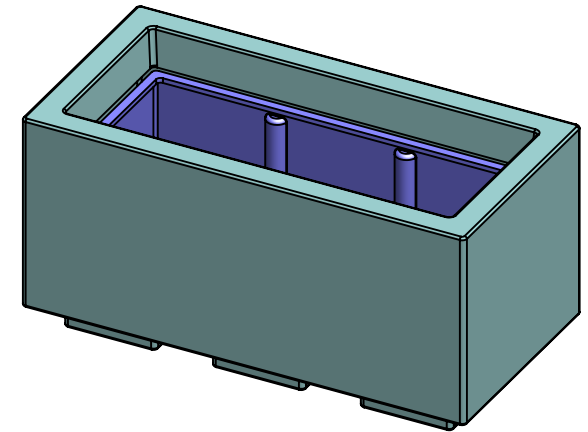

SECTION A-A

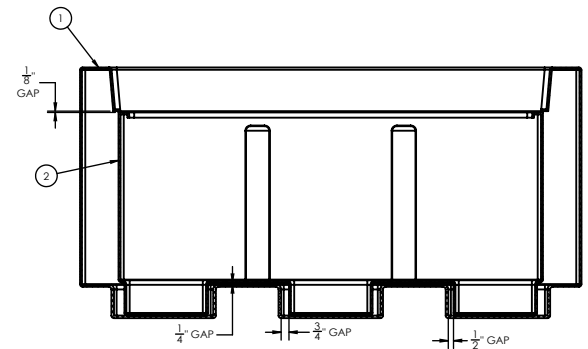
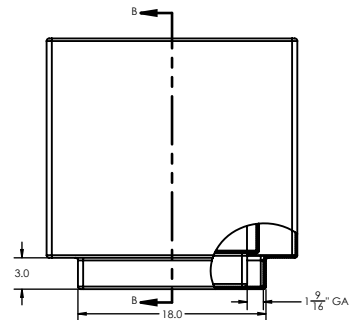

SECTION B-B

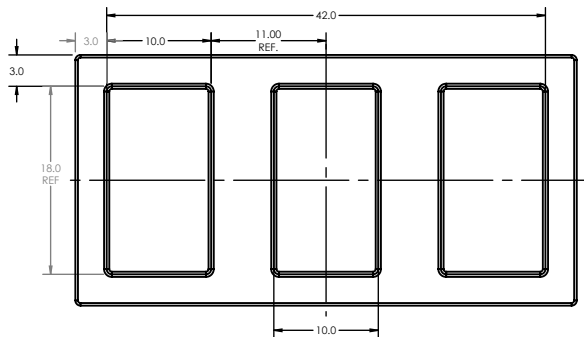

SPECS AT A GLANCE

TOP ID: 42" x 18"
 TOP OD: 48" x 24"
 BASE ID: 42" x 18"
 BASE OD: 48" x 24"
 HEIGHT: 24"
 WEIGHT: 66 LBS

NOTE:

COMBINED ASSEMBLY TO WEIGH APPROX. 55.7 LBS. AFTER TRIMMING AT 3/16" WALL.



TITLE

Millennium Rectangular Assembly

PART#

TSR48-24

DRAWN
KT

SIZE

MATERIAL
LLDPE Resin

DWG NO

DATE

03-16-21

REV

SCALE

WEIGHT

SHEET 1/3

DO NOT SCALE DRAWING.

All measurements are rounded to the closest quarter inch and may not be exact due to manufacturing variances.

This document contains TERRACAST[®] PROPRIETARY INFORMATION. No intellectual property right or license is granted by TERRACAST[®] in connection with it. It is delivered on the express condition that the document and the information contained in it shall be treated as confidential, shall not be used for and purpose other than that for which it is hereby delivered (the use and maintenance of the product supplied). It shall not be disclosed in whole or part to third parties and shall not be duplicated in any manner without TERRACAST[®]'s prior written consent.

TerraCast[®]

PRODUCTS

TERRACAST PRODUCTS LLC
 4400 NW 19TH AVENUE, UNIT K
 POMPANO BEACH, FL 33064
 305-895-9525
 INFO@TERRACASTPRODUCTS.COM

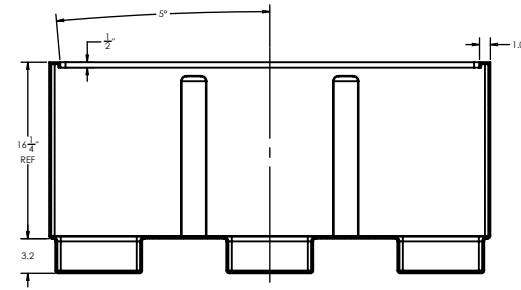
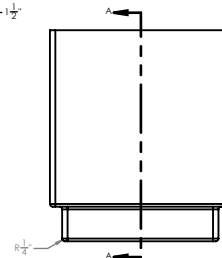
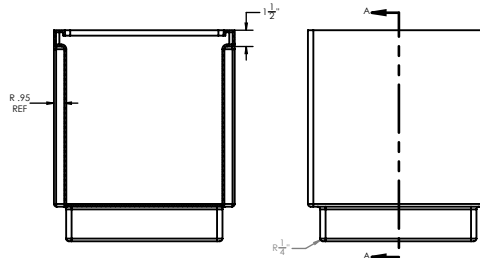
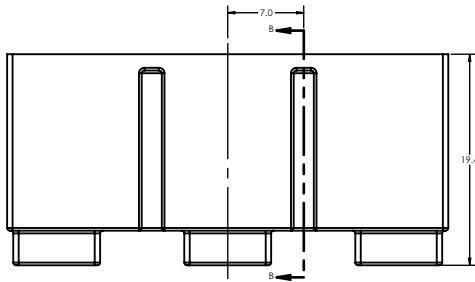
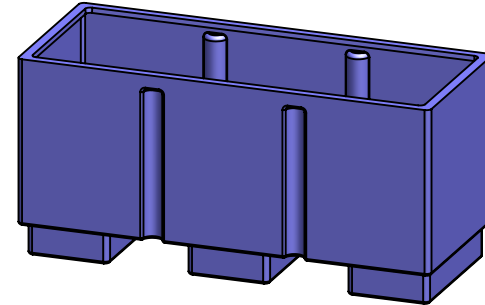
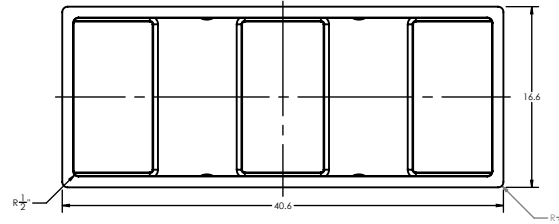

SECTION A-A

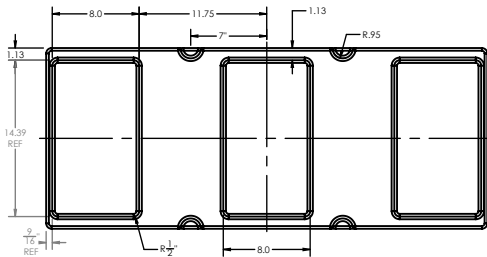

SPECS AT A GLANCE

TOP ID: 38.5" x 14.5"
 TOP OD: 40.5" x 16.5"
 BASE ID: 38.5" x 14.5"
 BASE OD: 40.5" x 16.5"
 HEIGHT: 19.5"
 WEIGHT: 29 LBS

NOTE:
 PART TO WEIGH APPROX. 19.34 LBS. AFTER TRIMMING AT 3/16" WALL.



TerraCast[®] PRODUCTS				
TITLE Millennium Rectangular Liner				
PART# TSR48-24-Liner			DRAWN KT	
SIZE	MATERIAL	DWG NO	DATE	REV
	LLDPE Resin		03-16-21	
SCALE		WEIGHT	SHEET 2/3	

DO NOT SCALE DRAWING.
 All measurements are rounded to the closest quarter inch and may not be exact due to manufacturing variances.
 This document contains TERRACAST[®] PROPRIETARY INFORMATION. No intellectual property right or license is granted by TERRACAST[®] in connection with it. It is delivered on the express condition that the document and the information contained in it shall be treated as confidential, shall not be used for and purpose other than that for which it is hereby delivered (the use and maintenance of the product supplied). It shall not be disclosed in whole or part to third parties and shall not be duplicated in any manner without TERRACAST[®]'s prior written consent.

TerraCast[®]

PRODUCTS

TERRACAST PRODUCTS LLC
 4400 NW 19TH AVENUE, UNIT K
 POMPANO BEACH, FL 33064
 305-895-9525
 INFO@TERRACASTPRODUCTS.COM

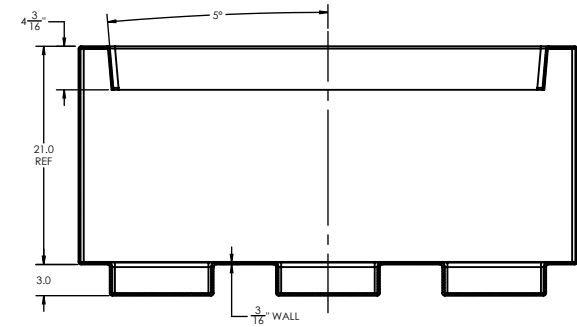
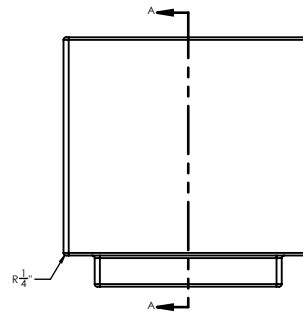
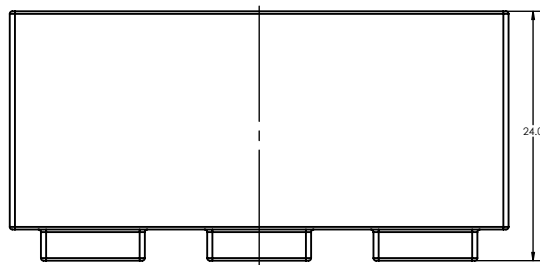
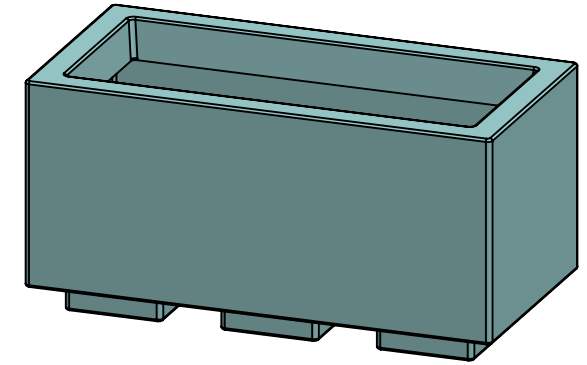
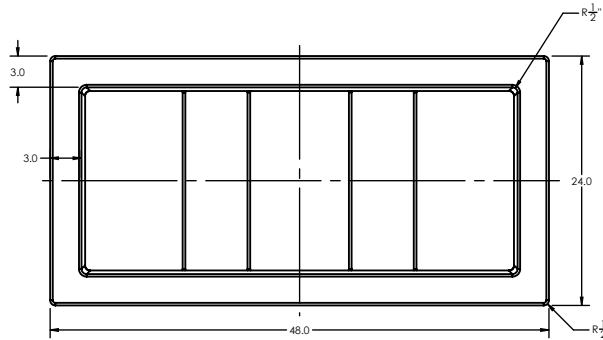

SECTION A-A

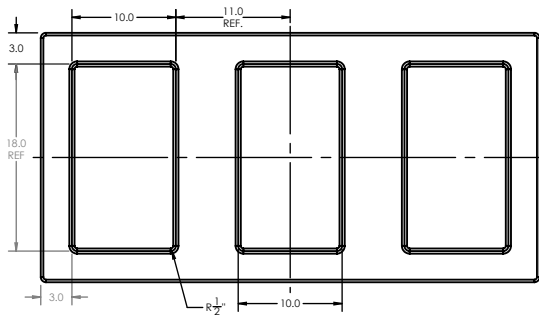

SPECS AT A GLANCE

TOP ID: 42" x 18"
 TOP OD: 48" x 24"
 BASE ID: 42" x 18"
 BASE OD: 48" x 24"
 HEIGHT: 24"
 WEIGHT: 37 LBS

NOTE:
 PART TO WEIGH APPROX. 36.36 LBS. AFTER TRIMMING AT 3/16" WALL.

TerraCast[®]
 PRODUCTS

TITLE

Millennium Rectangular

PART#

TSR48-24

DRAWN
 KT

SIZE

MATERIAL
 LLDPE Resin

DWG NO

DATE

03-16-21

REV

SCALE

WEIGHT

SHEET 3/3

DO NOT SCALE DRAWING.

All measurements are rounded to the closest quarter inch and may not be exact due to manufacturing variances.

This document contains TERRACAST[®] PROPRIETARY INFORMATION. No intellectual property right or license is granted by TERRACAST[®] in connection with it. It is delivered on the express condition that the document and the information contained in it shall be treated as confidential, shall not be used for and purpose other than that for which it is hereby delivered (the use and maintenance of the product supplied). It shall not be disclosed in whole or part to third parties and shall not be duplicated in any manner without TERRACAST[®]'s prior written consent.