

PROJECT _____

TYPE _____

VOLTAGE _____

POST TOP FIXTURE

TC41T

COMMERCIAL LIGHTING

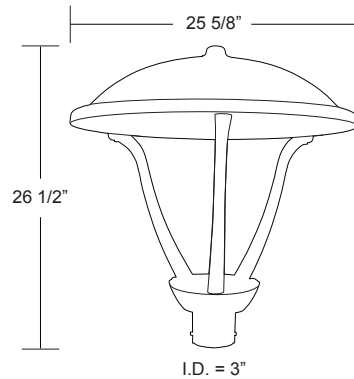

EPA 0.86ft²
WT 25lbs
 IES FILES AVAILABLE



SPECIFICATIONS

- Cast Aluminum Housing
- Stainless Steel Set Screws
- Black, White, or Bronze Finish
- Clear Glass Lens
- ETL Listed for Wet Locations



LIGHT SOURCE OPTIONS

- DEDICATED LED SYSTEM - L
- 120-277V, 50/60Hz
 - 150W or 250W Metal Halide Equivalent
 - Estimated 50,000 Hrs L ₇₀
 - Surge Supression
 - 4000K CCT, 80 CRI
 - Type 5 (Standard) or Type 3 Distribution
 - 5 Year Warranty

GUIDE CODE: TC41TC-L40C-BK

CALL FOR PHOTOMETRIC INFORMATION

ITEM #	LENS	LED LIGHT SOURCE	CCT	COLOR	OPTIONS
TC41T	GLASS C-Clear Lens	120-277V DEDICATED LED		BK -Black BZ -Bronze WH -White	T3 -Type 3 Distribution (Type 5 Standard)
		L40 -40W 3500lm L80 -85W 6100lm	C-4K		